

# STUART

## CH CI Centrifugal Pumps

The CH Cast Iron pump is a compact, high performance pump designed for continuous operation and will deliver flow rates up to 216 litres per minute and heads up to 46 metres.

60 Hz



**1 YEAR**  
GUARANTEE

From **50 dB(A)**  
Quiet Operation

### Features

- Centrifugal single stage pump
- Flow rates up to 216 litres per minute and heads up to 46 metres
- Standard control
- Cast iron pump body and stainless steel impeller
- Continuously rated
- 1 year guarantee

### Application

- The CH CI centrifugal range is designed to pump clean water. Other clean, non aggressive, non explosive liquids with similar characteristics to water may be pumped. Please consult Stuart Turner Ltd for guidance

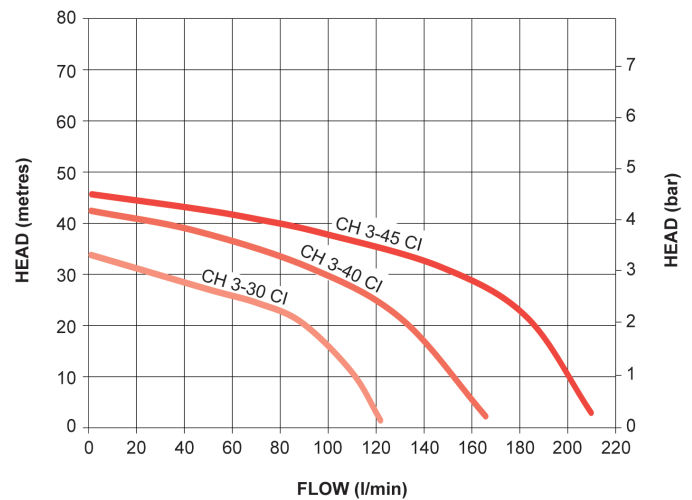

Pump Model		CH 3-30 CI 60 Hz 46672	CH 3-40 CI 60 Hz 46717	CH 3-45 CI 60 Hz 46718
General	Guarantee	1 year		
Features	Pump type	Centrifugal		
	Mechanical seal	Nitrile / Carbon / Ceramic		
	Priming vent plug	✓	✓	✓
Materials	Pump body	Cast iron		
	Impeller	Stainless steel		
Performance	Maximum head (closed valve)	34 metres	42 metres	46 metres
	Performance @ 50 l/min	28 metres	37 metres	43 metres
	Performance @ 90 l/min	21 metres	32 metres	39 metres
	Maximum flow	127 l/min	165 l/min	216 l/min
	Minimum static inlet pressure	0.5 bar (5 metres)		
	Maximum static inlet pressure	2.8 bar (28 metres)		
	Maximum viscosity	50 secs redwood no 1 9.5 centistokes		
	Maximum working pressure*	600 kPa (6 bar)		
	Maximum ambient air temperature	50 °C		
	Min / Max water temperature	Min 4 °C / Max 65 °C		
	Suction lift**	4.6 metres		
Connections	Pump connections	G 1 female	G 1¼ female (inlet), G 1 (outlet)	G 1¼ female (inlet), G 1 (outlet)
Motor	Type	Induction, auto-reset thermal trip		
	Duty rating	Continuous (S1)		
Electrical	Power supply (Vax/Ph/Hz)	220 V a.c. / 1 / 60 Hz		
	Current - full load	5.2 Amps	8.1 Amps	11 Amps
	Power P1	1100 Watts	1748 Watts	2395 Watts
	Power P2	759 Watts	1224 Watts	1677 Watts
	Fuse rating	13 Amps		
Physical	Enclosure protection	IP44		
	Length	290 mm	324 mm	
	Width	190 mm	211 mm	
	Height - excluding hoses	240 mm	260 mm	
	Weight - including fittings	13.15 Kg	18.25 Kg	21.05 Kg

\* The maximum pressure that can be applied to the pump under any installation conditions.

\*\* With footvalve fitted.

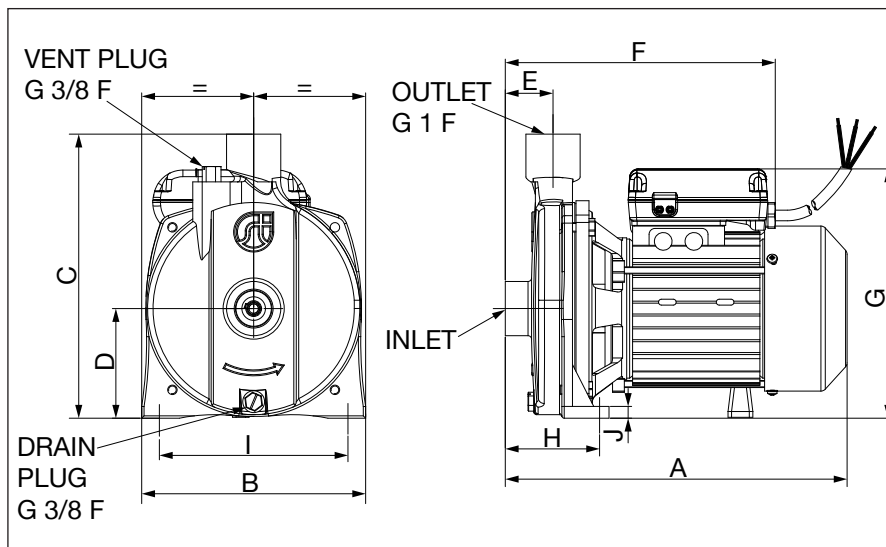

Pump Description	CH 3-30 CI	CH 3-40 CI	CH 3-45 CI
Dimension 'A'	290 mm	324 mm	324 mm
Dimension 'B'	190 mm	211 mm	211 mm
Dimension 'C'	240 mm	260 mm	260 mm
Dimension 'D'	93 mm	110 mm	110 mm
Dimension 'E'	45 mm	51 mm	51 mm
Dimension 'F'	230 mm	245 mm	245 mm
Dimension 'G'	211.5 mm	234 mm	234 mm
Dimension 'H'	80 mm	96 mm	96 mm
Dimension 'I'	160 mm	163 mm	163 mm
Dimension 'J'	10 mm	10 mm	10 mm
Inlet	G 1 F	G 1¼ F	G 1¼ F

Stuart Turner Limited reserves the right to amend specifications without notice.

Stuart Turner Ltd, Henley-on-Thames, Oxfordshire RG9 2AD Tel: +44 (0) 1491 572655 Fax: +44 (0) 1491 573704  
 TechAssist Helpline +44 (0) 800 31 969 80  
[www.stuart-turner.co.uk](http://www.stuart-turner.co.uk)

Pt. No. 20456 Issue 4119/2-01