

# stuart

## CH 3-30 CI Centrifugal Pump

The CH 3-30 CI centrifugal pump features end suction and vertical delivery and is designed for continuous operation. This compact, high performance pump delivers flow rates up to 120 l/min and heads up to 32 metres.



### Features

- Centrifugal pump design
- End suction, vertical delivery
- Long life seal
- Continuously rated induction motor
- Cast iron body and stainless steel impeller
- Priming vent plug and drain plug
- Flow rate up to 120 l/min

### Application

- The CH 3-30 CI centrifugal pump is designed to pump clean water. Other clean, non aggressive, non explosive liquids with similar characteristics to water may be pumped. Please consult Stuart Turner Ltd for guidance.

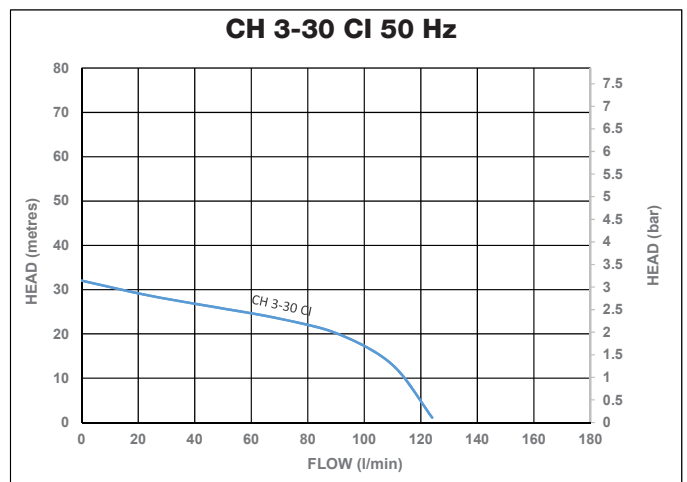

For further advice on selecting the correct pump call  
or e-mail [info@stpumps.co.uk](mailto:info@stpumps.co.uk)

**pumpassist**  
HELPLINE +44 (0) 800 31 969 80

**stuart**

Pump Model		CH 3-30 CI 50Hz 46671
General	Guarantee	1 year
Features	Pump type	Centrifugal
	Mechanical seal	Nitrile / Carbon / Ceramic
	Priming vent plug	✓
Materials	Pump body	Cast Iron
	Impeller	Stainless steel
Performance	Maximum head (closed valve)	32 metres
	Performance @ 50 l/min	25 metres
	Performance @ 90 l/min	17 metres
	Maximum flow	120 l/min
	Minimum static inlet pressure	0.5 bar (5 metres)
	Maximum static inlet pressure	2.8 bar (28 metres)
	Maximum viscosity	50 secs redwood no 1 9.5 centistokes
	Maximum working pressure*	600 kPa (6 bar)
	Maximum ambient air temperature	50 °C
	Min / Max water temperature	Min 4 °C / Max 65 °C
	Suction lift**	4.6 metres
Connections	Pump connections	G 1 female
Motor	Type	Induction, auto-reset thermal trip
	Duty rating	Continuous (S1)
Electrical	Power supply / phase / frequency	230 V a.c. / 1 / 50 Hz
	Current (full load)	4.8 Amps
	Power consumption	1050 Watts
	Fuse rating	13 Amps
Physical	Enclosure protection	IP44
	Length	290 mm
	Width	190 mm
	Height (excluding hoses)	240 mm
	Weight (including fittings)	13.15 Kg

\* The maximum pressure that can be applied to the pump under any installation conditions.

\*\* With footvalve fitted.

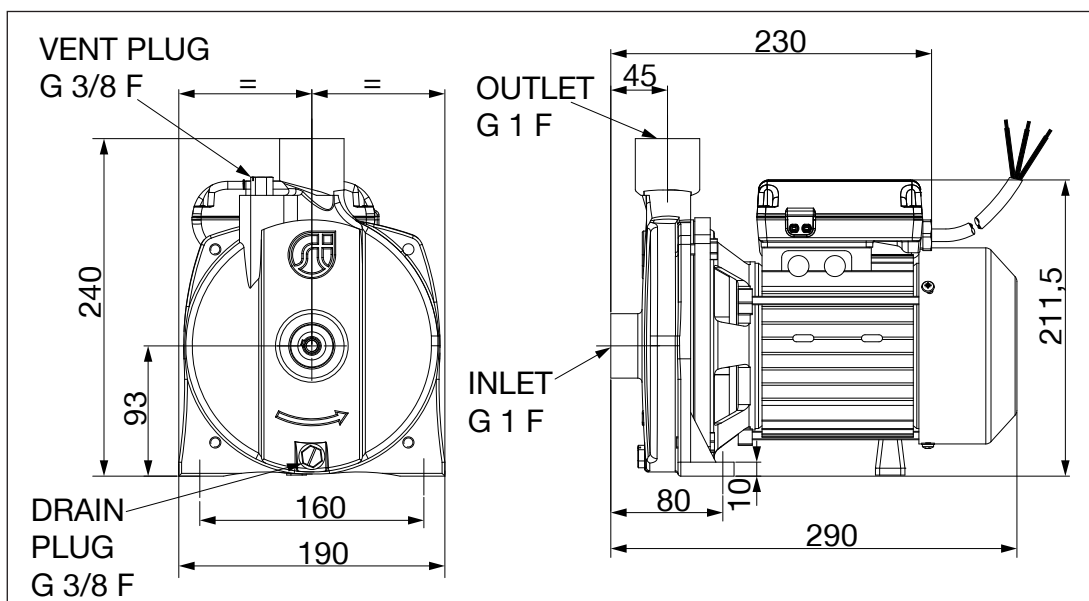

Stuart Turner Limited reserves the right to amend specifications without notice.